

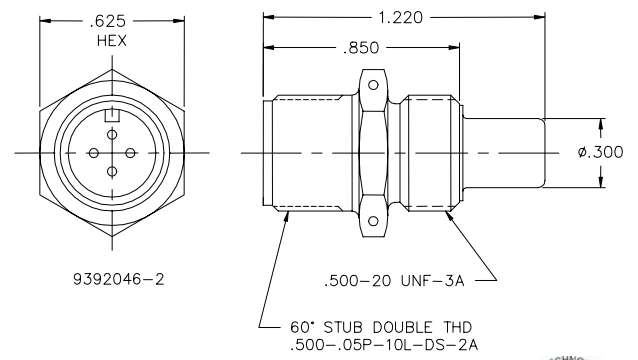

24225 GARNIER STREET • TORRANCE • CALIFORNIA 90505-5355 • U.S.A.
 TELEPHONES: (310) 784-2100 • (800) 733-0321 • FAX: (310) 326-0797
 E-mail: marketing@hstc.com

Harness Release Cartridge used on US Air Force Advanced Concept Ejection Seat (ACES II)	Datasheet	Page 1 of 2	Orig. date: 11 AUG03 Rev. A: 20JUL06
DEVICE	INITIATOR, Dual Bridge		DISPOSITIF
TYPE	Model PC-163-2- PN 9392046-2		REFERENCE
NSN	1377-01-368-5411ES		Stock Nombre Nationale
1. PERFORMANCES <ul style="list-style-type: none"> All-Fire current (Bruceton Method) No-fire current Ignition time Hermeticity Redundancy Action Time Slug Velocity 	3.5 A(R< 0,999 95%) +77°F 1A/1W – 5 min (-65°F +200°F) Max. 7ms (I= 3.5A) < 10 ⁻⁶ atm. Cm ³ / s (He) b.a.f Dual Bridgewires 25 ms maximum 200 ± 35 ft/sec		1. PERFORMANCES <ul style="list-style-type: none"> Courant de feu 100% (Method de Bruceton) Courant de non-feu Temps de fontionnement hérmécité Redondance Temps de Action Velocite de Limace
2. MECHANICAL CHARACTERISTICS <ul style="list-style-type: none"> Weight Electric connection <p style="text-align: center;">MATERIALS</p> <ul style="list-style-type: none"> Body Leads or connector Hermetic seal <ul style="list-style-type: none"> Feed through 	> 12 g Screw thd, .500-.05P.10.L-DS-2A 304L Stainless steel 52 Alloy pins Glass to metal seal		2. CARACTERISTICQUES MECANIQUES <ul style="list-style-type: none"> Masse Connexion électrique <p style="text-align: center;">MATERIAUX</p> <ul style="list-style-type: none"> Corps Câblage ou connecteur Hermécité <ul style="list-style-type: none"> Passage électrique
FIXING MODE	Thread 1/2-20 UNF-3A		MODE DE FIXATION
INSTALLATION TORQUE	95 – 105 inch pounds		TORSION D' INSTALATION
3. ELECTRICAL CHARACTERISTICS <ul style="list-style-type: none"> Bridgewire number Bridgewire resistance Insulation resistance RF Sensitivity Dielectric strength Static sensitivity <ul style="list-style-type: none"> All leads shorted to case Between leads 	2 1.05 ± 0.1 Ω > 2 Meg Ω / 500 VDC 1 x 10 ⁴ to 4 x 10 ¹⁰ cycles/second > 100 μ A / 200 VAC 25 Kv / 500 pF /500 Ω resistor		3. CARACTERISTIQUES ELECTRIQUES <ul style="list-style-type: none"> Nombre de ponts-fusibles Résistance du filament Résistance d'isolement RF susceptibilité Rigidité diélectrique Décharges électrostatiques <ul style="list-style-type: none"> Entre circuit et masse Entre fils
CURRENT RATINGS			COURANTS LIMITES
<ul style="list-style-type: none"> Nominal firing current All-fire current Safe no-fire current for testing 	> 3.5 A / 7 ms max. 3.5 A (R<0,999 95%) +77°F < 10mA		<ul style="list-style-type: none"> Courant de mise à feu nominal Courant de feu 100% Courant maxi de contrôle





24225 GARNIER STREET • TORRANCE • CALIFORNIA 90505-5355 • U.S.A.
 TELEPHONES: (310) 784-2100 • (800) 733-0321 • FAX: (310) 326-0797
 E-mail: marketing@hstc.com

Harness Release Cartridge used on US Air Force Advanced Concept Ejection Seat (ACES II)	Datasheet Page 2 of 2	Orig. date: 11 AUG03 Rev. A: 20JUL06
4. PYROTECHNIC CHARACTERISTICS <ul style="list-style-type: none"> • Initiator type • Principal pyrotechnic load 	80 mg Hi-Temp	4. CARACTERISTIQUES PYROTECHNIQUES <ul style="list-style-type: none"> • Type d'initiateur • Charge pyrotechniques principale
5. ENVIRONMENTAL TEST SPECIFICATIONS <ul style="list-style-type: none"> • Mechanical shock • Acceleration • Sinusoidal vibration • Random vibration • Humidity • Thermal shock • Thermal vacuum • Operating temperature • Storage life 	100g 6 shock impacts /11ms 3axis 20 g / 120 sec 25 Hz 2g 10 – 100 .01 - .08 6db/oct 100 – 400 0.8 constant 400 – 2 KC 0.6 – 0.16 3db/oct MIL-E-5277C Proc. 1 -65°F +200°F 20 cycles 1hr +200°F 1x10 ⁻⁶ Torr (650K alt) -200°F 1x10 ⁻⁶ Torr (96 hr) -70°F +200°F 5 years	5. RESISTANCE AUX CONDITIONS D'ENVIRONNEMENT <ul style="list-style-type: none"> • Chocs mécaniques • Accélération • Vibrations sinusoïdales • Vibrations aléatoires • Humidité • Chocs thermiques • Vide thermique • Températures de fonctionnement • Durée de stockage
6. DEVELOPMENT STATUS <ul style="list-style-type: none"> - References: <ul style="list-style-type: none"> • Development date • Acceptance test report • Last verification of qualification date - Flight applications: <ul style="list-style-type: none"> • Projects • Dates • Users 	Qualified to MIL-C-25918 1980's 9392046-3785 1993 US Air Force A-10, F-15, F-16, F-22, B-1 & B 2 US Air Force Fighter & Bomber Aircraft 1980's to present US Air Force & US Allies	6. CONDITIONS DE DEVELOPPEMENT <ul style="list-style-type: none"> - Références: <ul style="list-style-type: none"> • Date du développement • Rapport de qualification • Contrôls de qualification ultérieurs - Applications spatiales: <ul style="list-style-type: none"> • Projets • Dates • Utilisateurs



ISO 9001 A9813